



Installation Instructions:

(Part # SB76882)

2007-2011 Jeep JK 4Door

XRC Rear Armor Corner Guard Kit

NOTE: Carefully read entire instructions thoroughly before attempting to install this part.



WARNING: Check with Local and State laws before installing this accessory!

Parts Included:	Qty	Parts Included:	Qty
93-7037 Rear Armor Fender: Drvr	1	90-6777 Hardware Pack: Inner Fender Liner	1
93-7047 Rear Armor Fender: Pass	1	Plastic Retainers	14
93-7055 Fender Lip Guard: Drvr	1	90-6778 Hardware Pack: Nutcert	1
93-7056 Fender Lip Guard: Pass	1	3/8" Nutcert	14
90-4324 Inner Fender Liner: Drvr	1	90-6774 Hardware Pack: Nutcert Installation	1
90-4325 Inner Fender Liner: Pass	1	96-5951 Nutcert Tool	1
93-7054 Liner Tab	4	3/8" Star Washer	1
90-6776 Hardware Pack: Fender	1	3/8" X 2" Socket Head Bolt	1
3/8" X 1" SS Button Head Bolt	37	3/8" Gr. 8 Flat Washer	1
3/8" Flat Washer	48	3/8" Gr. 8 Nut: Un-plated	1
3/8" Nylock Nut	34	90-6781 Hardware Pack: Fender Weather Stripping	1
3/8"-16 X 1" Hex Bolt Gr. 5	13	90-4330 Fender Weather Stripping	1

IMPORTANT!: In order to install these fenders you will have to drill holes in the body.

INSTALLATION:

Step 1: Working on one side of the vehicle at a time, unbolt and remove the steps and/or sliders from the vehicle. Save hardware for reinstallation.

Step 2: Remove the fender flairs and inner fenders from the vehicle.

Step 3: Remove the license plate box from the vehicle.

Step 4: Test fit the license plate template on the vehicle. Be sure the mounting holes and the tailgate line up with the template. Due to factory manufacturing variations, the template may need to be adjusted.

For Technical Support/Warranty Information please call 310-762-9944



Installation Instructions:

(Part # SB76882)

2007-2011 Jeep JK 4Door

XRC Rear Armor Corner Guard Kit

Step 5: Unbolt and remove the tail lights from the vehicle. Save the hardware for reinstallation.

Step 6: Remove the rear bumper from the vehicle if it appears that it will interfere with the installation of the rear fender armor. Save the hardware for reinstallation.

Step 7: Test fit the rear armor fender (93-7037 **drv**r and 93-7047 **pass**) using C-clamps around the outside of the panels through the windows. Fig B & C.

IMPORTANT!: *Align the upper edge of the armor with the body line. The bottom rear edge of the armor should line up with the radius of the lower edge. The front of the armor should be aligned so that it provides proper clearance for door operation. Fig B & C.*

Step 8: Once the armor fender is properly aligned and clamped into place, mark the appropriate holes for drilling. Fig B & C.

NOTE: *If you are reinstalling the license plate box to the vehicle, place the supplied drill template on the rear of the driver side fender against the tailgate. Using the holes in the template mark the driver side armor fender for drilling.*

Step 9: Remove the armor fender and center punch the previously applied marks for drilling. Carefully drill the fender mounting marks out to 33/64" and the license plate holes to 3/4" and 3/8". Fig B & C.

IMPORTANT!: *DO NOT drill through the interior panels.*

Step 10: Install the 3/8" nutserts into the previously drilled 33/64" holes in the quarter panel.

NOTE: *If you do not have a professional nutsert installation tool, use the 2 1/2" X 3/8" socket head bolt, 3/8" nut and washer. Install the nutsert into the 1/2" hole on the vehicle. Thread the nut up as far on the 3/8" bolt as it will go and then follow that with the washer. Thread the bolt, nut, washer, nutsert tool (96-5951) and star washer assembly*

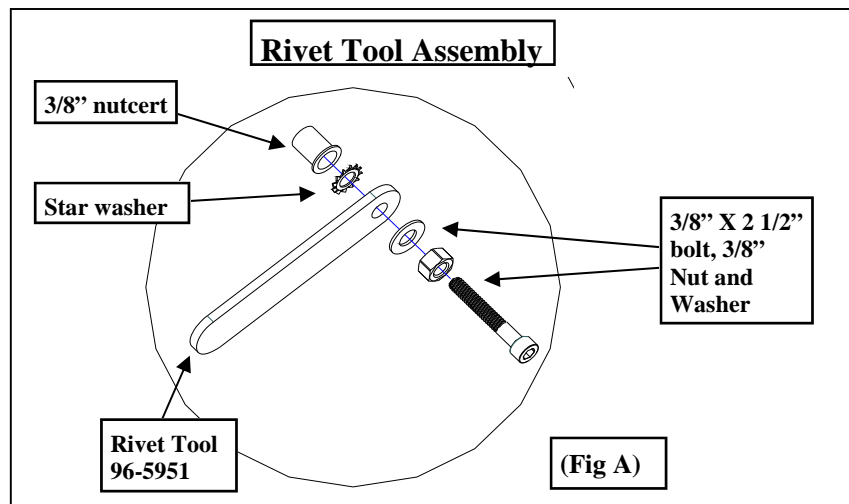

For Technical Support/Warranty Information please call 310-762-9944



Installation Instructions:

(Part # SB76882)
2007-2011 Jeep JK 4Door
XRC Rear Armor Corner Guard Kit

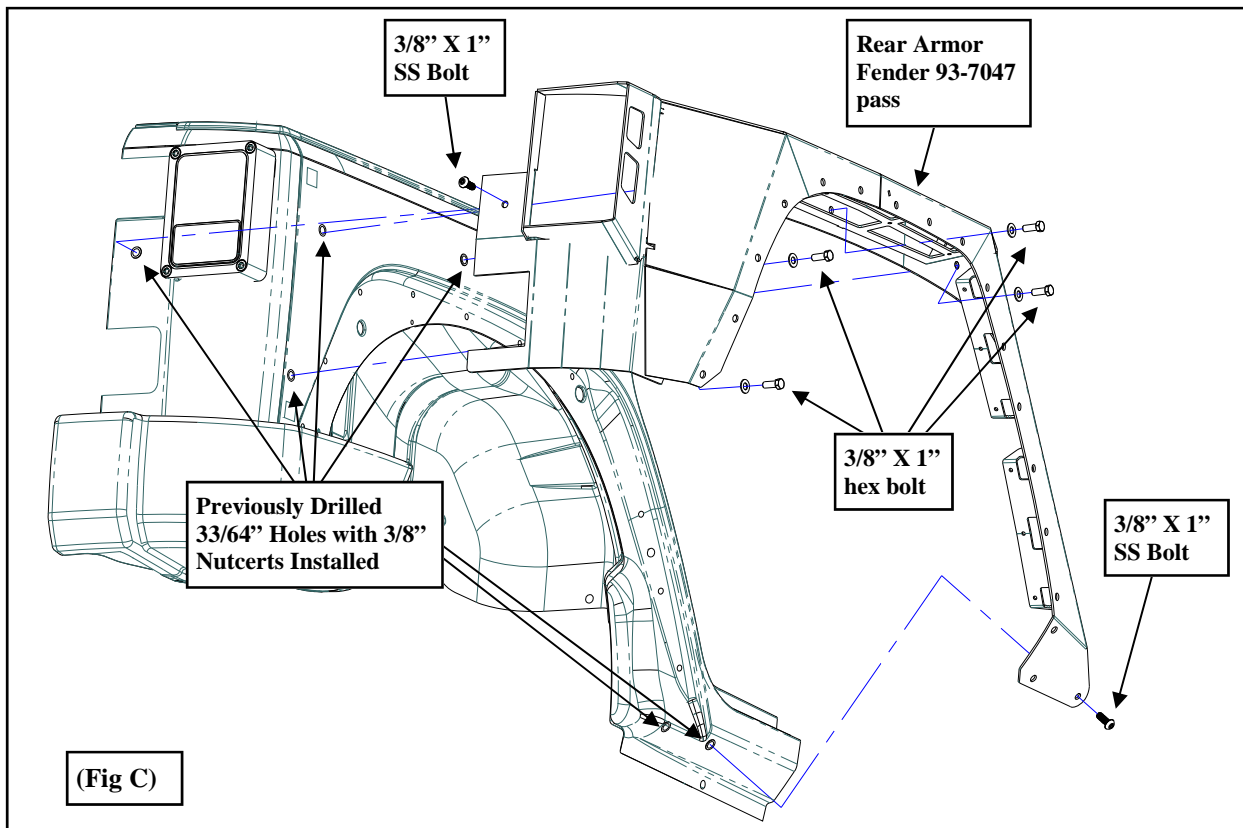
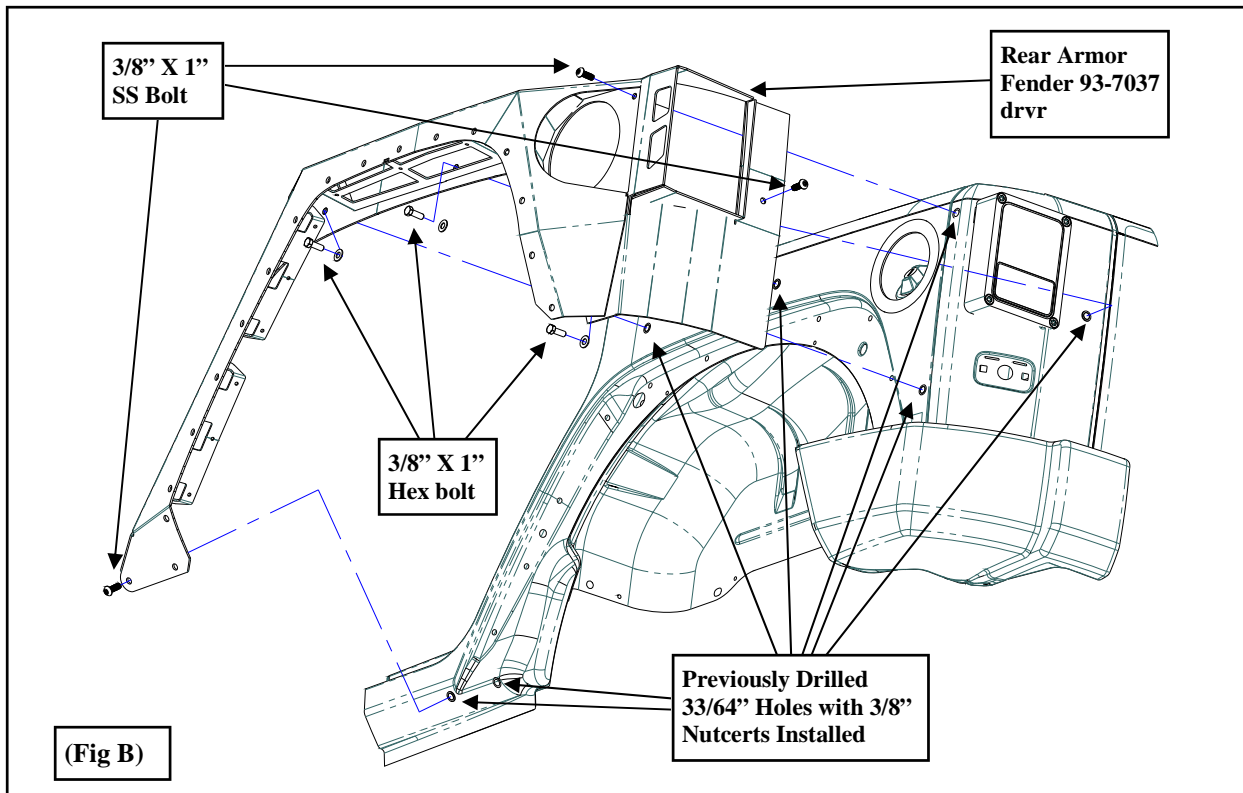

For Technical Support/Warranty Information please call 310-762-9944



Installation Instructions:

(Part # SB76882)
2007-2011 Jeep JK 4Door
XRC Rear Armor Corner Guard Kit

into the nutcert. (Fig. A) While holding the 3/8" bolt with an Allen wrench, tighten the nut and washer down against the nutcert. Use the nutcert tool and star washer to keep the nutcert body from spinning while tightening the 3/8" bolt. Once the nutcert is properly installed into the vehicle remove the 3/8" bolt, nut, washer, nutcert tool (96-5951) and star washer.

Step 11: Install the supplied fender weather stripping (90-4330) to the upper and front edges of the armor. This will provide a weatherproof seal to the body of the vehicle.

Step 12: Reinstall the armor fender (93-7037 *drv* and 93-7047 *pass*), using the clamps, in it's appropriate position and check the alignment of the nutcerts and the mounting holes in the armor. Slot the holes in the armor if necessary to avoid cross threading the bolts. Fig. B & C.

NOTE: The nutcerts are prone to spinning if not installed properly or cross threaded. Be sure to start the bolts by hand in the nutcerts.

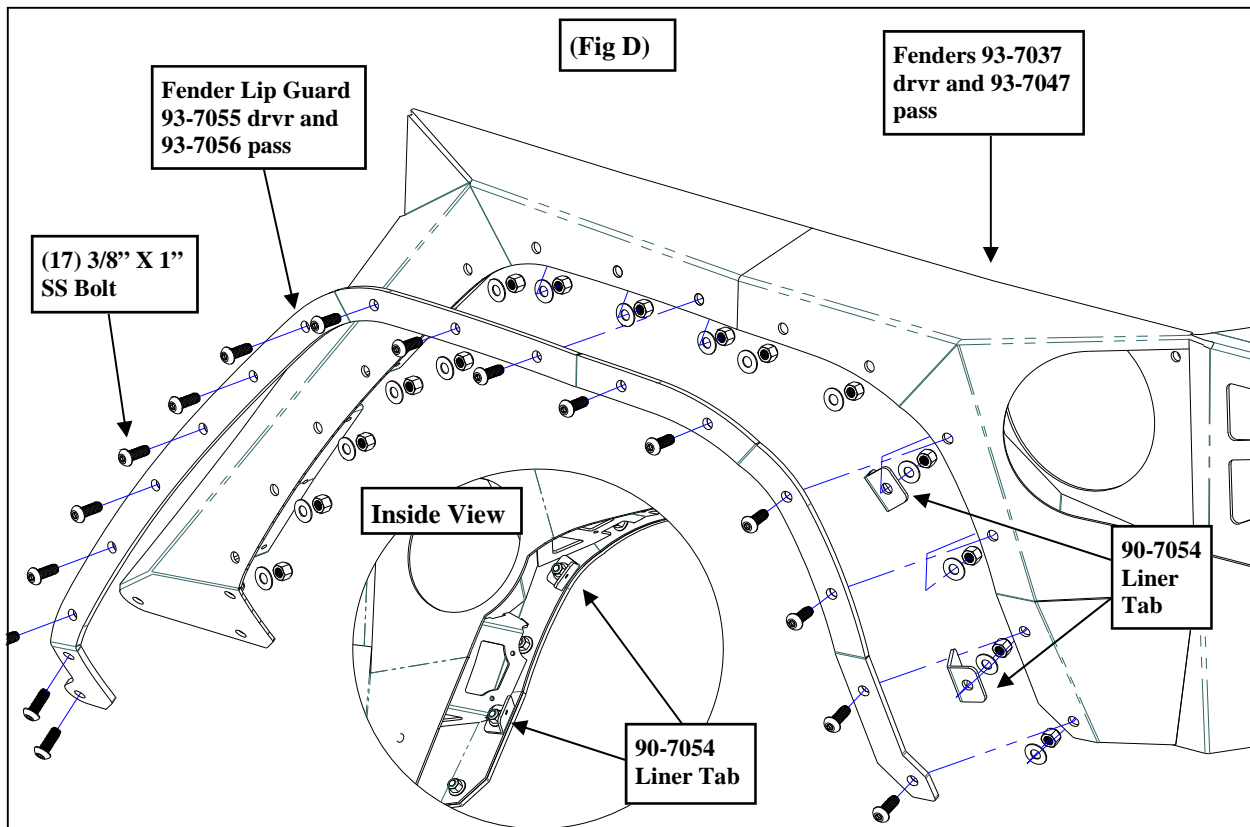

Step 13: Remove the clamps and secure the armor fender using the supplied 3/8" X 1" bolts and hardware. Be sure to start all the bolts by hand to avoid cross threading the bolts. Fig. B & C.

NOTE: Be sure to use the Stainless 3/8" X 1" bolts on the exposed mounting holes.

For Technical Support/Warranty Information please call 310-762-9944



Installation Instructions:

(Part # SB76882)
2007-2011 Jeep JK 4Door
XRC Rear Armor Corner Guard Kit

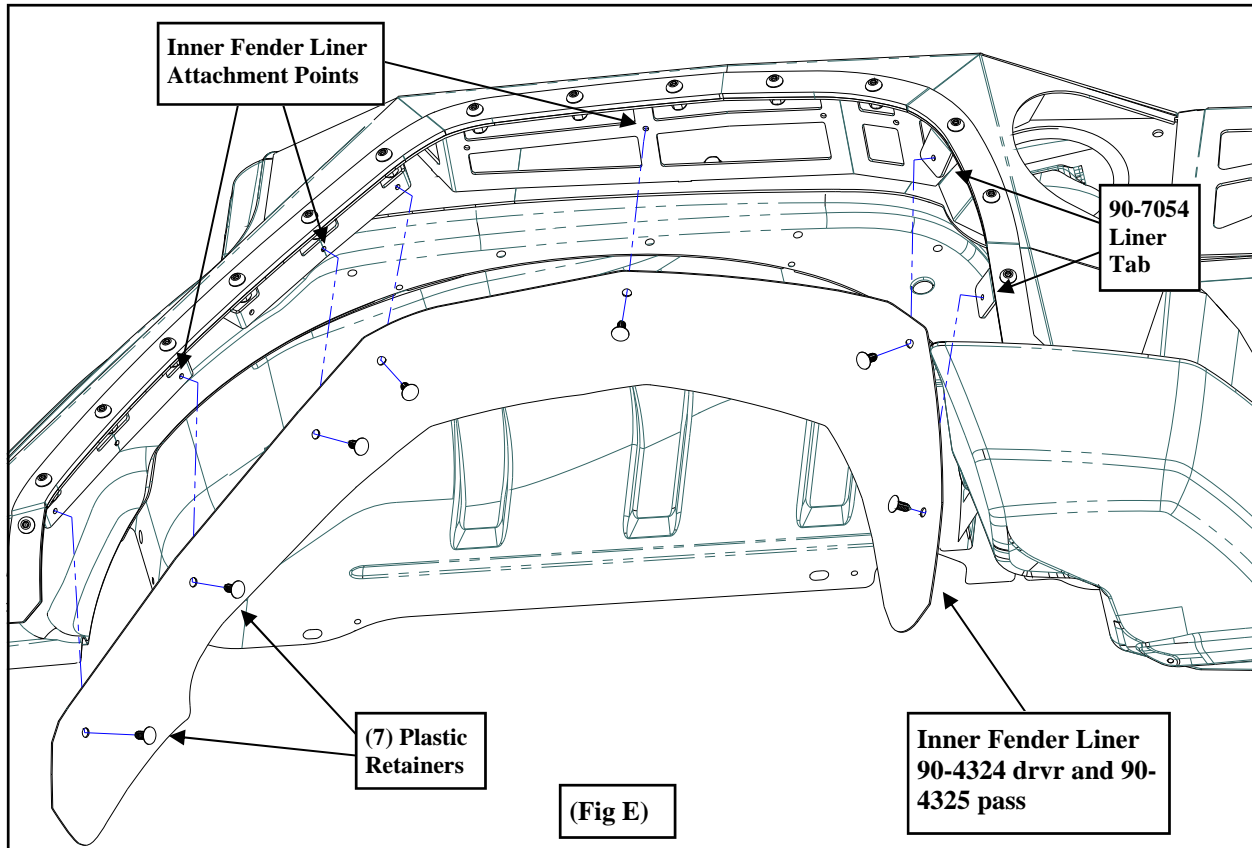

Step 14: Install the fender lip guard (**93-7055 drv** and **93-7056 pass**) to the outside of the wheel well using the supplied **3/8" X 1"** stainless button head bolts. Fig. D.

Step 15: Install the inner fender liner tabs (**93-7054**) to the (2) rear bolts (**2nd** up from the bottom and the **4th** up from the bottom). Fig. D.

Step 16: Install the inner fender liner (**93-4324 drv** and **93-4325 pass**) into the armor using the supplied plastic retainers. Start in the middle and work your way to the outside edge. Fig. E.

Step 17: Reinstall the **OE** tail lights to the tail light bezels on the armor fenders using the previously removed **OE** hardware.

Step 18: Repeat the previous steps on the remaining side of the vehicle.

Step 19: Reinstall the previously removed rear bumper using the previously removed hardware. Torque according to manufacturers specifications.

Step 20: If you are reinstalling the license plate, route the wiring harness through the armor fender and reconnect the light wiring clip. Install the license plate box to the armor fender using the previously removed **OE** hardware.

For Technical Support/Warranty Information please call 310-762-9944



Installation Instructions:

(Part # SB76882)

2007-2011 Jeep JK 4Door

XRC Rear Armor Corner Guard Kit

Step 21: Reinstall the steps and/or sliders from the vehicle using the previously removed OE hardware.

Step 22: Torque all OE hardware according to manufacturers specifications or the supplied hardware according to the torque chart on page 6. Installation is now complete.

Bolt Torque and ID						
Decimal System			Metric System			
All Torques in Ft. Lbs.						
Bolt Size	Grade 5	Grade 8	Bolt Size	Class 9.8	Class 10.9	Class 12.9
5/16	15	20	M6	5	9	12
3/8	30	45	M8	18	23	27
7/16	45	60	M10	32	45	50
1/2	65	90	M12	55	75	90
9/16	95	130	M14	85	120	145
5/8	135	175	M16	130	165	210
3/4	185	280	M18	170	240	290

<p>1/2-13x1.75 HHCS</p> <p>Grade 5 Grade 8 (No. of Marks + 2)</p> <p>D T L X</p>	<p>M12-1.25x50 HHCS</p> <p>D T L X</p>
---	--

G = Grade (Bolt Strength)	P = Property Class (Bolt Strength)
D = Nominal Diameter (Inches)	D = Nominal Diameter (Millimeters)
T = Thread Count (Threads per Inch)	T = Thread Pitch (Thread Width, mm)
L = Length (Inches)	L = Length (Millimeters)
X = Description (Hex Head Cap Screw)	X = Description (Hex Head Cap Screw)

For Technical Support/Warranty Information please call 310-762-9944



Installation Instructions:

(Part # SB76882)

2007-2011 Jeep JK 4Door

XRC Rear Armor Corner Guard Kit

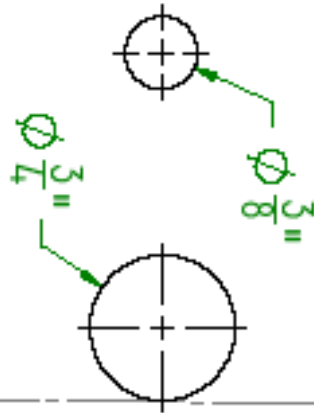

UP

TAILGATE



Installation Instructions:

(Part # SB76882)
2007-2011 Jeep JK 4Door
XRC Rear Armor Corner Guard Kit

Limited Warranties

Smittybilt's products are covered under the following limited warranties only. Note that the duration of the limited warranty differs according to the material and finish of the product purchased. Subject to the duration and conditions of the limited warranty stated below, Smittybilt warrants to the original retail purchaser that its products are free from defects in material and workmanship. All other warranties and representations express or implied, are hereby disclaimed, including fitness for merchantability and buyer's intended use or purpose. All parts are sold "AS IS" except for the limited warranties granted herein. Buyer assumes all risks as to the selection, suitability and performance of all goods and products selected. This limited warranty does not cover damage or impairment in any part due to misuse, improper installation, accident or contact with on-road or off-road hazards, product modification, improper or inadequate cleaning and/or maintenance. Smittybilt is not responsible for items damaged during shipping. This warranty is not transferable from the original buyer. For the original Buyer to be eligible for the limited warranty coverage, the Buyer must provide proof of purchase. Smittybilt strongly recommends returning the warranty registration card.

Customer's remedy hereunder shall be limited only to repair or replacement (at Smittybilt's option) of any defective part(s) returned to Smittybilt at customer's expense. The determination of whether or not a returned part is defective or subject to coverage under the limited warranties stated herein shall be made at Smittybilt's sole discretion.

Duration of Limited Warranty

Limited Lifetime Warranty on Stainless Steel Products -

Smittybilt stainless steel products carry the foregoing limited repair or replacement warranty against workmanship and defects in the material so long as the original purchaser retains the original stainless steel parts.

Limited Five (5) Year / 50,000 Mile Pro-Rata Warranty (whichever occurs first) on Dual-Stage Powder Coating Products -

Smittybilt dual-stage powder coated products carry the foregoing limited repair or replacement warranty for a period of (5) years or 50,000 miles (whichever occurs first) from date of purchase against workmanship and defects in the material, provided that any claim submitted after (2.5) years from date of purchase shall, if accepted, be satisfied by Smittybilt offering customer a credit on the purchase of a replacement product equal to fifty percent (50%) of customer's initial purchase price.

Limited Three (3) Year / 36,000 Mile Pro-Rata Warranty (whichever occurs first) on Chrome Products-

Smittybilt chrome products finished carry the foregoing limited repair or replacement warranty for a period of three (3) years or 36,000 miles against workmanship and defects in the material (whichever occurs first) from the date of purchase.

To assure product quality, Smittybilt reserves the right to change product design, material, specification and finishes without prior notice to customers. This limited warranty gives you specific legal rights and you may also have other rights, which may vary from state to state. Some states do not allow limitations on how long an implied warranty lasts, so the above limitations may not apply as to you. Also, some states do not allow the exclusion or limitation of incidental or consequential damages, so the above limitations or exclusions may not apply to you. Smittybilt reserves the right to discontinue product lines and substitute products, or provide other remedies than those listed in this limited warranty for those discontinued products.

For Technical Support/Warranty Information please call 310-762-9944

Smittybilt, 400 W Artesia, Compton, CA 90220