



Installation Instructions:

(Part # SB2740)

I-Rack

(Intelligent Racking System)

NOTE: Carefully read entire instructions thoroughly before attempting to install this part.

CAUTION!: Adding excessive weight to the tire carrier may cause failure.

NOTE: If your installation requires multiple gas can mounts, an additional gas can mounting kit (SB2740-01) can be purchased separately.

Parts Included	Qty	Parts Included	Qty
90-4249 Jack Mount Stud	2	90-6723 Hardware Pack: Jack & Gas Can	1
90-5761 Wing Bolt 1 1/4": Main Body	2	1/2" Hex Nut Gr. 8	6
90-5763 Wing Bolt 5 1/2": Gas Can Mount	1	1/2" Split Lock Washer	6
90-5765 1/2" Wing Nut: Jack Mount Stud	2	1/2" SAE Flat Washer	6
90-5767 Gas Can Retainer	1	P1029 Hardware Pack: Jack Mount Stud	2
93-5769 Stem Mount	1	Cushion	2
90-4251 Gas Can Upper Mount	1	Retainer	2
93-5771 Gas Can Lower Mount	1	Nut	1
93-5774 I-Rack Main Body	1	90-5777 Nut Plate: Main Body	1
90-2466 Jack Mount Stud Spacer	2	90170A212 Quick Disconnect Pin	2

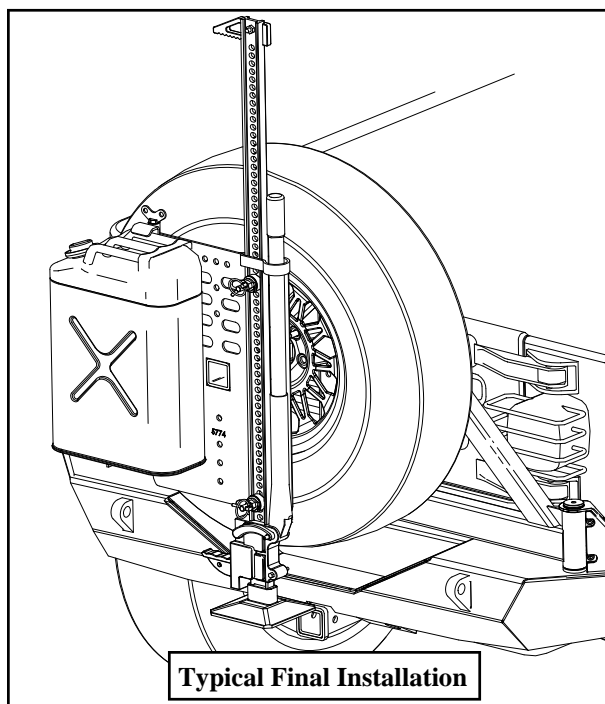

For Technical Support/Warranty Information please call 310-762-9944



Installation Instructions:

(Part # SB2740)

I-Rack

(Intelligent Racking System)

Main Body Mounting Instructions:

Step 1: Remove the spare tire from the tire carrier. (Fig. A)

Step 2: Install the stem mount (93-5769) onto the spare tire mounting studs. Reinstall the spare tire and secure with the previously removed lug nuts. (Fig. A)

NOTE: Jeep TJ will use the smaller bolt pattern and the Jeep JK will use the larger bolt pattern.

Step 3: Carefully install the I-Rack main body (93-5774) receiver onto the stem mount (91-5769) and secure using the supplied nut plate (90-5777) and 1 1/4" wing bolt (90-5761) in one of the side locating oval holes that best fits your application. (Fig. A)

Step 4: Once installation of the I-Rack main body is completed install the remaining 1 1/4" wing bolt (90-5761) into the welded nut on the bottom of the I-rack body receiver. This will remove any excess play in the assembly and secure it firmly in place. (Fig. A)

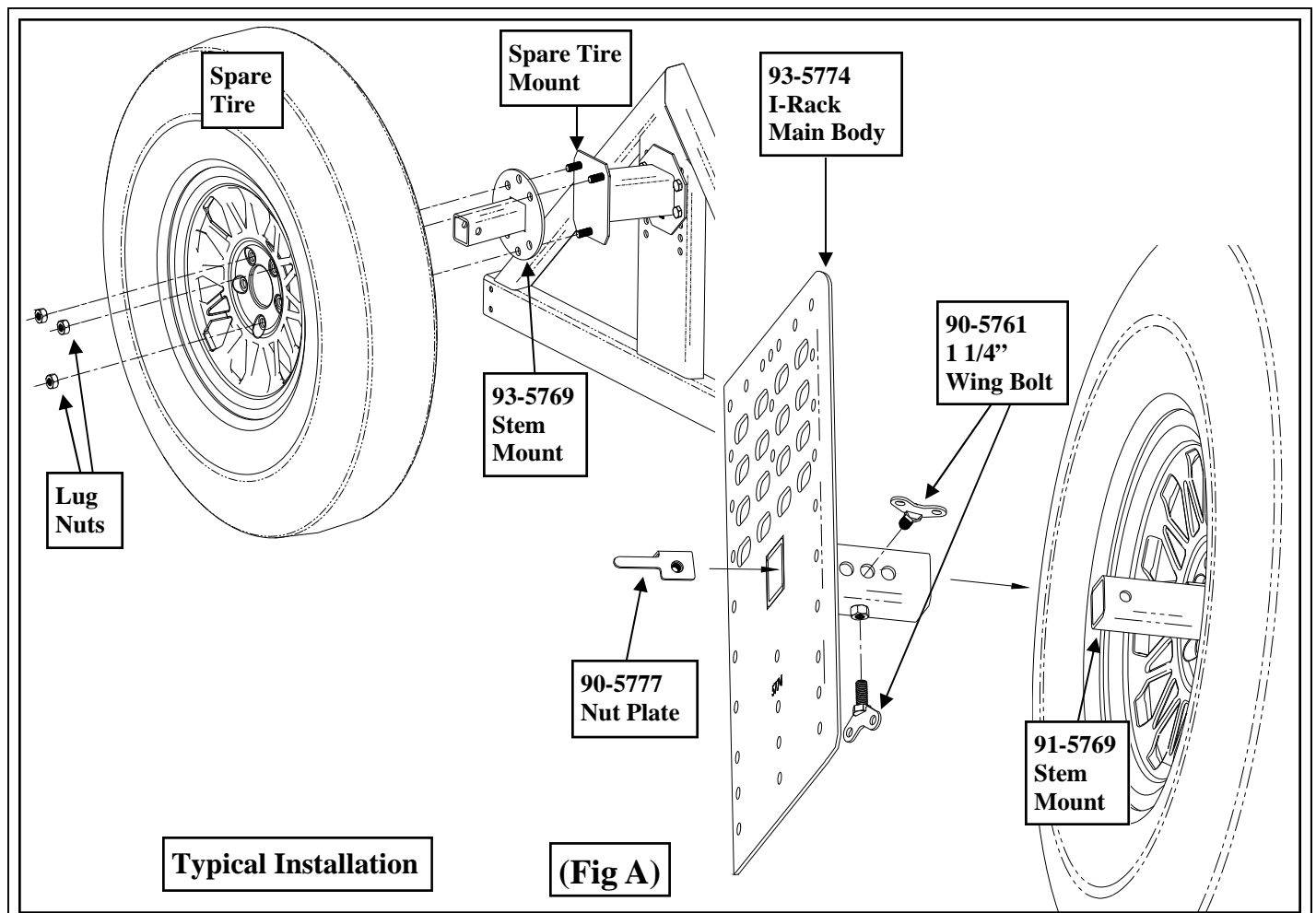

For Technical Support/Warranty Information please call 310-762-9944



Installation Instructions:

(Part # SB2740)

I-Rack

(Intelligent Racking System)

Jack Mounting Instructions:

Step 1: Choose mounting the holes that mount the jack at your desired height. Install the jack mount studs (90-4249) into the previously chosen holes in the I-Rack main body and secure using the 1/2" hardware. (Fig B)

Step 2: Install the Jack onto the mounting studs (90-4249) using the supplied spacers (90-2466), cushions and retainers from pack (P-1029). Secure using 1/2" wing nuts (90-5765). (Fig B)

Step 3: Tighten the 1/2" wing nuts (90-5765) until the quick disconnect pin holes are exposed. Install the quick disconnect pins (90170A212) into the jack mount studs. (Fig B)

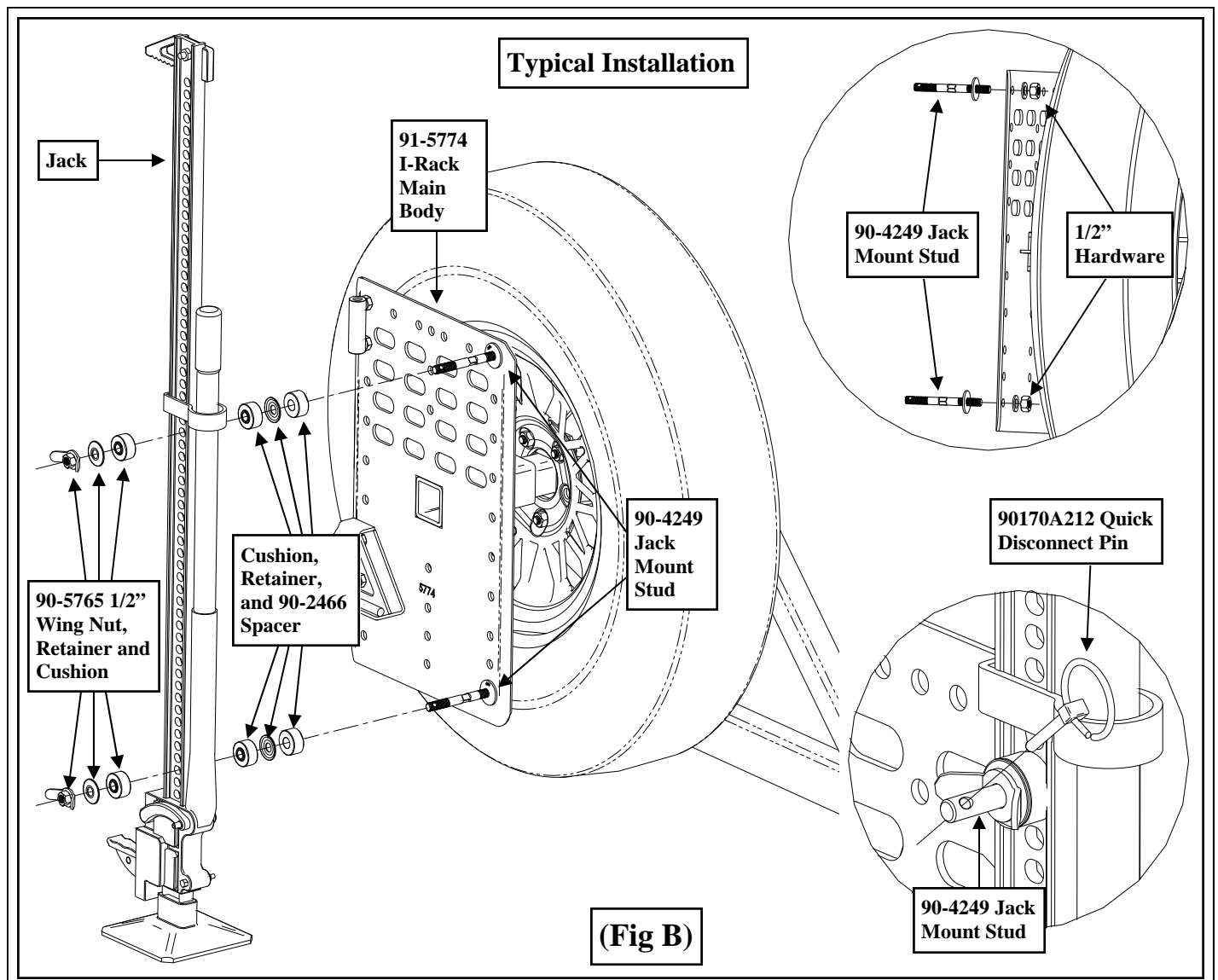

For Technical Support/Warranty Information please call 310-762-9944



Installation Instructions:

(Part # SB2740)

I-Rack

(Intelligent Racking System)

Gas Can Mounting Instructions:

Step 1: Choose the lower mounting holes that mount the gas can at your desired height. Install the gas can lower mount (93-5771) to the I-Rack main body and secure using the supplied 1/2" nuts and hardware. (Fig C)

Step 2: Assemble the upper mount by installing the 5 1/2" wing bolt (90-5763) through the gas can retainer (90-5767) and threading it into the gas can upper mount (90-4251). (Fig C)

Step 3: Install the gas can to the lower mount. Secure the top of the gas can to the I-Rack main body by installing the assembled upper mount onto the I-Rack main body and securing it using the supplied 1/2" nuts and hardware. (Fig C)

Step 4: Use the 5 1/2" wing bolt (90-5763) to tighten the gas can retainer over the handle of the gas can to secure it in place. (Fig C)

Step 5: Installation is now complete.

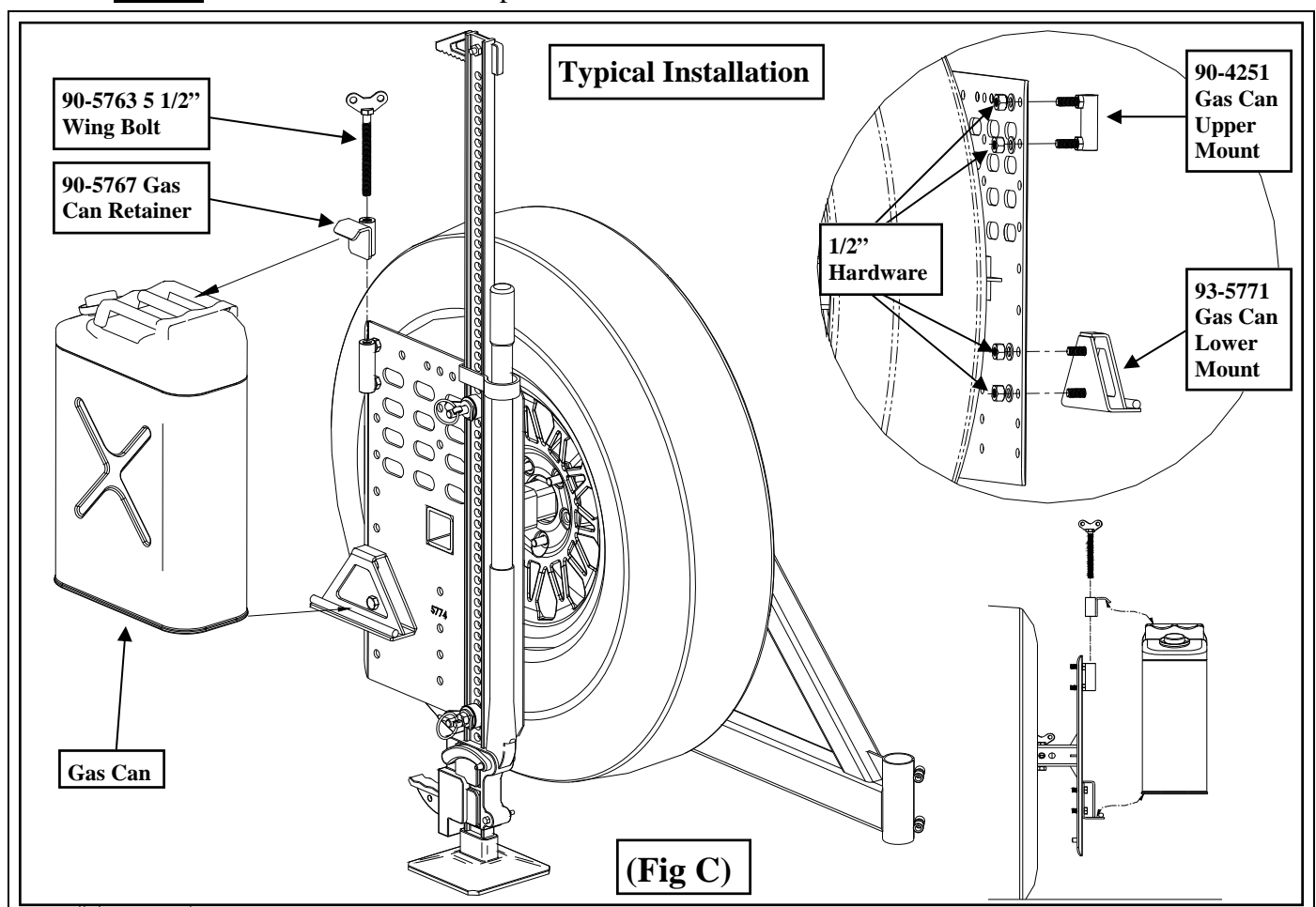

For Technical Support/Warranty Information please call 310-762-9944



Installation Instructions:

(Part # SB2740)
I-Rack
 (Intelligent Racking System)

Bolt Torque and ID						
Decimal System			Metric System			
All Torques in Ft. Lbs.						
Bolt Size	Grade 5	Grade 8	Bolt Size	Class 9.8	Class 10.9	Class 12.9
5/16	15	20	M6	5	9	12
3/8	30	45	M8	18	23	27
7/16	45	60	M10	32	45	50
1/2	65	90	M12	55	75	90
9/16	95	130	M14	85	120	145
5/8	135	175	M16	130	165	210
3/4	185	280	M18	170	240	290

<p>1/2-13x1.75 HHCS D T L X</p> <p>Grade 5 Grade 8 (No. of Marks + 2)</p>	<p>M12-1.25x50 HHCS D T L X</p>
---	--

<p>G = Grade (Bolt Strength) D = Nominal Diameter (Inches) T = Thread Count (Threads per Inch) L = Length (Inches) X = Description (Hex Head Cap Screw)</p>	<p>P = Property Class (Bolt Strength) D = Nominal Diameter (Millimeters) T = Thread Pitch (Thread Width, mm) L = Length (Millimeters) X = Description (Hex Head Cap Screw)</p>
---	--

Product cleaning and maintenance instructions

Stainless Steel Finish – Aluminum polish may be used to polish small scratches and scuffs on the finish. Mild soap, window or glass cleaner may be used to clean the finish. **Dual state powder coat finish** – Mild soap, window or glass cleaner may be used to clean the finish. In order to protect the finish, you may wax your product on a regular basis with pure carnauba automotive wax. Do not use any types of soap, polish or wax that contains abrasive that could damage the finish. **Textured coated finishes** should be cleaned with a mild soap on a damp sponge. Do not apply polish or wax that requires to be removed by means of buffing. This type of wax is commonly used at car wash facilities. **Chrome Finish** – Mild soap, window or glass cleaner may be used to clean the finish. In order to protect the finish you should wax your product on a regular basis with pure carnauba automotive wax. Do not use any types of soap, polish or wax that contains abrasive that could damage the finish.

For Technical Support/Warranty Information please call 310-762-9944



Installation Instructions:

(Part # SB2740)
I-Rack
 (Intelligent Racking System)

Limited Warranties

Smittybilt's products are covered under the following limited warranties only. Note that the duration of the limited warranty differs according to the material and finish of the product purchased. Subject to the duration and conditions of the limited warranty stated below, Smittybilt warrants to the original retail purchaser that its products are free from defects in material and workmanship. All other warranties and representations express or implied, are hereby disclaimed, including fitness for merchantability and buyer's intended use or purpose. All parts are sold "AS IS" except for the limited warranties granted herein. Buyer assumes all risks as to the selection, suitability and performance of all goods and products selected. This limited warranty does not cover damage or impairment in any part due to misuse, improper installation, accident or contact with on-road or off-road hazards, product modification, improper or inadequate cleaning and/or maintenance. Smittybilt is not responsible for items damaged during shipping. This warranty is not transferable from the original buyer. For the original Buyer to be eligible for the limited warranty coverage, the Buyer must provide proof of purchase. Smittybilt strongly recommends returning the warranty registration card.

Customer's remedy hereunder shall be limited only to repair or replacement (at Smittybilt's option) of any defective part(s) returned to Smittybilt at customer's expense. The determination of whether or not a returned part is defective or subject to coverage under the limited warranties stated herein shall be made at Smittybilt's sole discretion.

Duration of Limited Warranty

Limited Lifetime Warranty on Stainless Steel Products -

Smittybilt stainless steel products carry the foregoing limited repair or replacement warranty against workmanship and defects in the material so long as the original purchaser retains the original stainless steel parts.

Limited Five (5) Year / 50,000 Mile Pro-Rata Warranty (whichever occurs first) on Dual-Stage Powder Coating Products -

Smittybilt dual-stage powder coated products carry the foregoing limited repair or replacement warranty for a period of (5) years or 50,000 miles (whichever occurs first) from date of purchase against workmanship and defects in the material, provided that any claim submitted after (2.5) years from date of purchase shall, if accepted, be satisfied by Smittybilt offering customer a credit on the purchase of a replacement product equal to fifty percent (50%) of customer's initial purchase price.

Limited Three (3) Year / 36,000 Mile Pro-Rata Warranty (whichever occurs first) on Chrome Products-

Smittybilt chrome products finished carry the foregoing limited repair or replacement warranty for a period of three (3) years or 36,000 miles against workmanship and defects in the material (whichever occurs first) from the date of purchase.

To assure product quality, Smittybilt reserves the right to change product design, material, specification and finishes without prior notice to customers. This limited warranty gives you specific legal rights and you may also have other rights, which may vary from state to state. Some states do not allow limitations on how long an implied warranty lasts, so the above limitations may not apply as to you. Also, some states do not allow the exclusion or limitation of incidental or consequential damages, so the above limitations or exclusions may not apply to you. Smittybilt reserves the right to discontinue product lines and substitute products, or provide other remedies than those listed in this limited warranty for those discontinued products.

For Technical Support/Warranty Information please call 310-762-9944

Smittybilt, 400 W Artesia, Compton, CA 90220